

Fits 19-30" TVs



Our universal enclosures are the perfect solution for integrating a TV into almost any outdoor environment or living space



Weather Protection

- Water-resistant sealed housing protects the TV in any environment
- Protects against external elements such as dust, dirt, rain and moisture
- Withstands drastic temperatures and sun exposure



Damage Protection

- Shatter-resistant ultra-clear polycarbonate shield to protect your television
- Manufactured with high molecular weight polyethylene outdoor plastics for ultimate durability



Theft Protection

- Riveted hinged shield provides a tight and secure fit
- Dual-chambered key locks provide added security and easy access
- Engineered to be theft and tamper resistant to protect against vandalism



Anti-glare

- Optional built-in anti-glare Lexan® shield available
- Order Code /AG

Weatherproof TV Enclosure

Fits 19-29" Televisions

The TV Shield is a weatherproof and secure enclosure designed with the residential consumer market in mind. Ideal for both outdoor and indoor areas, The TV Shield's lightweight universal design easily opens for a direct view of your TV, allowing you to watch, protect and secure any TV in almost any environment. The TV Shield universal enclosures protect TVs and video displays in residential and commercial environments worldwide.

WEATHERPROOF – Our sealed enclosure is water-resistant and the ultimate defense against extreme weather, sun exposure, rain, dust, bugs and other outdoor elements.

AFFORDABLE - The TV Shield is the most affordable TV enclosure on the market. Rather than making you purchase an expensive outdoor television, you can pair our enclosures with almost any TV and mount, making it the most affordable solution on the market.

LIGHT WEIGHT - Our units weigh 50-75% less than our competition and are made of lightweight, yet highly durable and long lasting outdoor plastics. Our largest unit only weighs 47lbs and our smallest unit weighs 15lbs.

TAMPERPROOF SECURITY - The TV Shield's dual-chambered key locks provide added security against vandalism, tampering and theft. The riveted hinged cover provides a tight and secure fit.

ELEGANT - The enclosures high molecular weight polyethylene black plastic and ultra-clear shield are designed to blend in with most outdoor lifestyles and match most current television designs. Custom orders and design combinations are available by special request.

UNIVERSAL - With the ability to fit almost any flat-panel TV, The TV Shield can accommodate televisions from 19 inches up to 60 inches. Our proprietary design mounts using any universal VESA mounting system.

VERSATILE - Whether in the open or closed position, you can enjoy watching television on your outdoor patio, pool deck or any setting you prefer.

DURABLE - The TV Shield's ultra-clear cover (shield) is manufactured using 1/4" thick shatter-resistant polycarbonate, the same material used to produce bullet proof glass, for the ultimate durability and screen protection.

MADE IN THE USA - The TV Shield television enclosure was designed, engineered and is manufactured in the USA from top quality materials.

LIMITED PRODUCT WARRANTY

12 Months warranty

DIMENSIONS

- Small: Fits all 19" to 29" Displays; most Units Up To 30"*
- min inside Dimensions: 701W x 489 H x 117" D (mm)
- max inside Dimensions: 711W x 501 H x 117 D (mm)
- Outside Dimensions: 803W x 590 H x 146 D (mm)
- Weight: 6.8kg

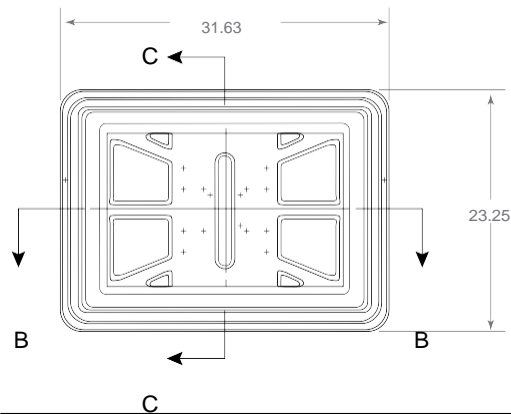
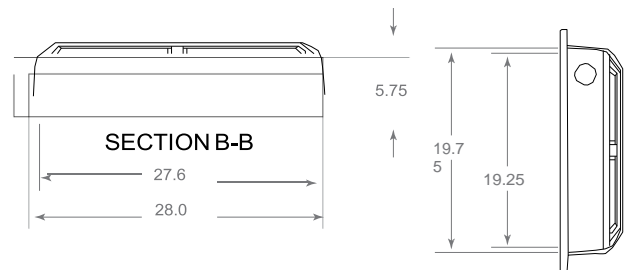

INCLUDED

- (1) The TV Shield
- (2) Foam Blocks for mounting
- (2) Prop arms Between Foam Blocks
- (1) Small Black Drawstring Bag,
- (6) Black Security Caps
- (4) Small grommets
- (4) Medium grommets
- (4) Large grommets
- (2) Keys for locks
- (1) 1 1/4" Round Black Handle
- (1) 1/2" Screw (Used to install handle)

AVAILABLE ACCESSORIES

Fans, Heaters, Cleaning Kit, Moisture gel case