

TR-WE45-A-IN PTZ Dome Wall Mount



Specifications

Bracket	TR-WE45-A-IN
Application	Indoor or outdoor, wall installation for PTZ dome camera
Dimensions(L x W x H)	216mmx141mmx314mm(8.5" x 5.6"x 12.4")
Weight	1.0kg(2.2lb)
Material	Aluminum alloy

Dimensions

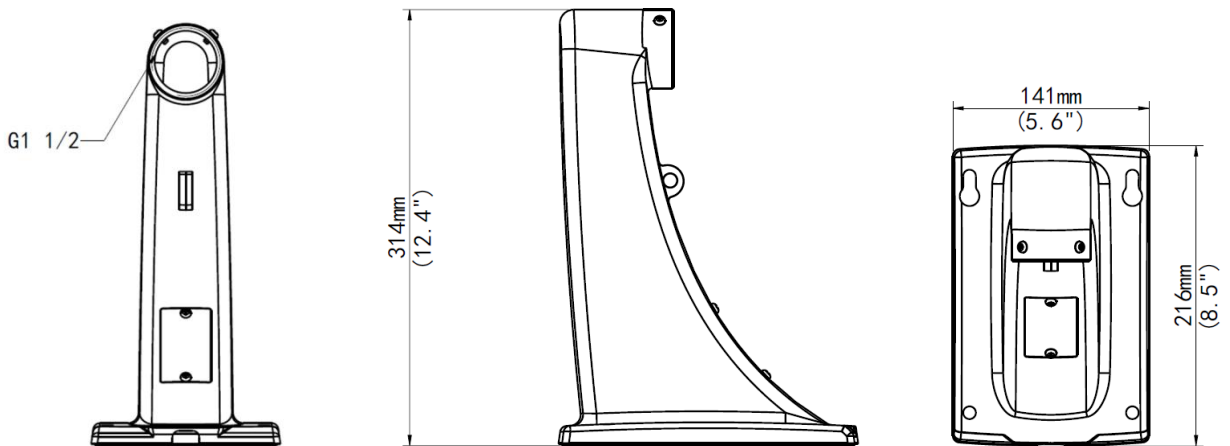

Zhejiang Uniview Technologies Co.,Ltd.

©2015 Zhejiang Uniview Technologies Co.,Ltd. All rights reserved.

*Product specifications and availability are subject to change without notice.