

Planned optical power levels Max +7dBm Min -12dBm. SAT @ 2150MHz Min off air level 75dBuV : TERR @ 790MHz Min off air level 55dBuV Max 70dBuV

**Replacement of an old
TMM55/30
To the new TMSA on system
repairs.**

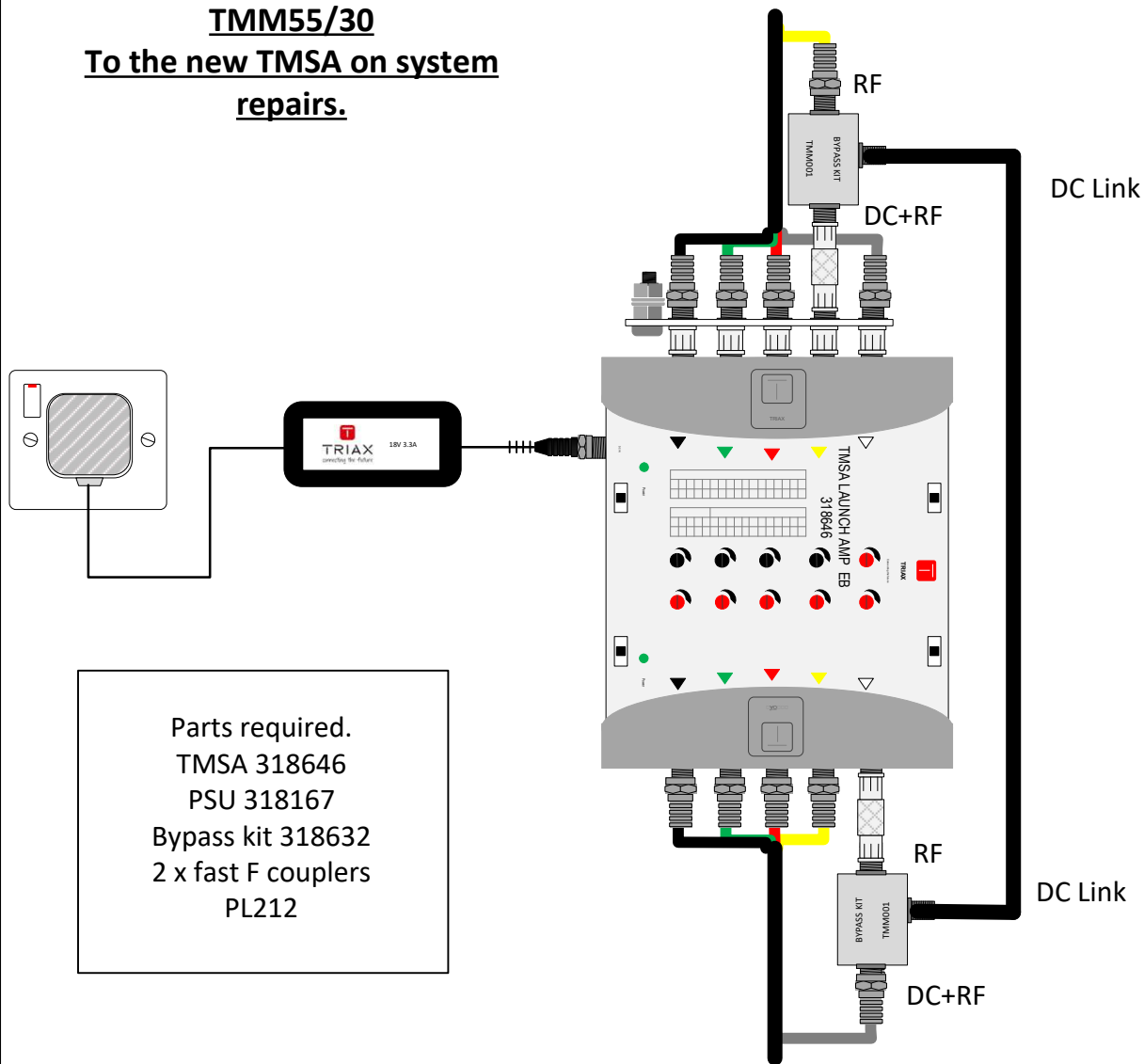

- Parts required.
 TMSA 318646
 PSU 318167
 Bypass kit 318632
 2 x fast F couplers
 PL212

ALL SYSTEMS MUST BE EARTH BONDED - TERMINATE ALL UNUSED OUTLETS

**DISH ARRAY MUST SIT WITHIN THE BUILDING LIGHTNING PROTECTION ZONE WITH CALCULATED SEPARATION
 SPD's (SURGE PROTECTION DEVICES) WILL BE NEEDED IF THIS IS BREACHED**